



SINGLE-ROTOR PRE-CRUSHERS

01.01.A

ALLIGATOR

FROM URBAN FOREST TO PRE-CRUSHED MATERIAL

TECHNICAL FEATURES

/ Very large feeding hopper for bulky material / Low-speed crushing rotor equipped with strong teeth / Hydraulic drive protected from overloads / Hydraulic drive protected from overloads / Discharge sizing screen for pre-crushed material.

BENEFITS

/ Drastic volume reduction of bulky recycling, i.e. from 60-80 to 130-150 kg/m³bd / Easier & cheaper transportation of pre-crushed material / Full protection from overloads, e.g. from foreign bodies / Compact, simple, versatile, highly reliable and efficient system / Minimum noise / Very low maintenance / Low energy consumption.

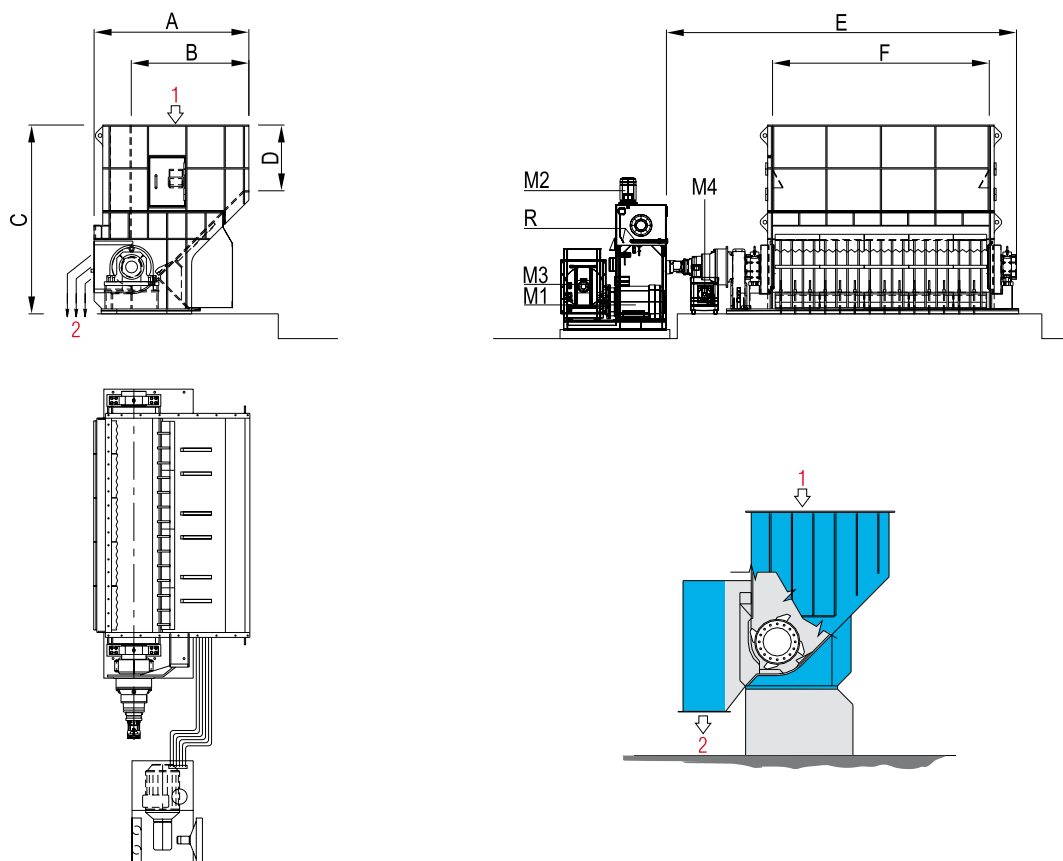

1 = INFEED M1 = MAIN MOTOR M3 = HEAT EXCHANGER FOR OIL R = RESISTORS FOR HEATING OIL
 2 = OUTFEED M2 = FEEDING HYDRAULIC UNIT M4 = HEAT EXCHANGER FOR GEAR BOX

Not binding data. We reserve the right of modification at any time without prior notice.

01.01.A

ALLIGATOR

FROM URBAN FOREST TO PRE-CRUSHED MATERIAL

OVERALL DIMENSIONS mm

MODEL	A	B	C	D	E	F
ALLIGATOR 80-350/240	2500	1900	3050	1060	5720	3500

*Open side for feeding

MODEL	CAPACITY** t/h	INSTALLED POWER kW					WEIGHT APPROX. KG
		M1	M2	M3	M4	R***	
ALLIGATOR 80-350/240	15-25	75-90	7,50	1,10	0,75	3 x 2	22000

According to type-volume of material and infeed efficiency *Resistors for heating oil - option